



# OWNER'S MANUAL

**MODELS FED-AMFM-1620-A, FED-AMFM-1625-A**

**FED-AMFM-2020-A, FED-AMFM-2025-A**

**HIGH EFFICIENCY MEDIA RETROFIT AIR CLEANER**

*IMPORTANT: PLEASE READ MANUAL BEFORE OPERATING UNIT*

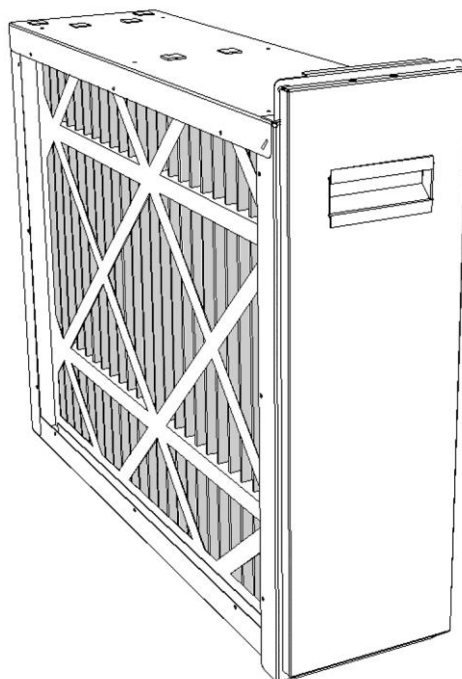

## Features

- High Efficiency MERV 11 Media Filter removes airborne pollutants as small as 0.3 micron
- Carbon Filters (optional) available for odor removal
- No maintenance except for filter replacement
- No electrical hook-up required
- Heavy gauge galvanized steel cabinet and powder-coat paint finish resist corrosion and provide trouble-free installation

**FOR TECHNICAL SUPPORT AND REPLACEMENT FILTERS CALL:  
[www.feddersusa.net](http://www.feddersusa.net) - [sales@feddersusa.net](mailto:sales@feddersusa.net)**

## SAFETY CONSIDERATIONS

Read and follow instructions carefully. Improper installation may damage Air Cleaner.

Understand the signal words **WARNING** and **CAUTION** which are present in the Owner's Manual. **WARNING** and **CAUTION** signify a hazard which could result in personal injury, property damage or death.

### WARNING

Before beginning any installation or modification, be certain that the main line electrical disconnect switch is in the OFF position. Electric shock could result. Tag disconnect switch with suitable warning labels.

**Only a heating/air conditioning installer or qualified service person should install your Air Cleaner, unless you are completely familiar with the necessary tools, equipment and potential hazards involved. If you plan to install this Air Cleaner yourself, please be aware that the improper use of any tool can be dangerous. The manufacturer will not assume any responsibility for failures due to incorrect installation procedures.**

Homeowners can perform the basic maintenance functions of replacing filters.

When working on the Air Cleaner, observe precautions in the Owner's Manual, labels attached to the unit, and other safety precautions that may apply. Follow all safety codes. Wear safety glasses and work gloves.

## WHAT THE AIR CLEANER DOES

Your Air Cleaner has been designed to remove atmospheric and household dust, coal dust, insecticide dust, mites, pollen, mold spores, fungi, bacteria, pet dander, cooking smoke and grease, tobacco smoke and more down to 0.3 micron (1/84,000 of an inch).

## BENEFITS

- Helps provide relief from allergy and asthma suffering.
- Helps prevent damaging black dust from staining walls, upholstery and window coverings, reducing the amount of time and money spent cleaning and redecorating.
- Helps eliminate unpleasant odors with optional carbon filters.
- Helps protect costly heating/cooling equipment, prolonging operating efficiency.

## HOW IT WORKS

Millions of airborne pollutants are carried through the return air ducts of the heating/cooling system to the Media Air Cleaner. Here the particles are captured by the media filter.

The media filter is constructed of continuous hydrophobic polyolefin fibres that will not shred or absorb moisture. The media's unique design features a structured density gradient with an electret charge for higher initial and sustained efficiency. The media is supported by an open steel mesh and enclosed by a high wet-strength beverage board. The filter has an Underwriter's Laboratories Class 2 rating.

The efficiency of the filter is MERV 11, based on the ASHRAE Standard 52.2. Test velocity is 492 feet/minute. An arrow indicates direction of air flow.

Composite Average Efficiency Value	Composite Minimum Range (Microns)	Average Composite Minimum Values
E1	0.3 - 1.0	26.0%
E2	1.0 - 3.0	65.5%
E3	3.0 - 10.0	85.4%

The clean air then passes through the carbon filters (3), where odors are adsorbed (optional). The carbon filter is a polyester pad impregnated with activated carbon. An aluminum frame is used to support the filter. Activated carbon with its naturally unique porous structure, allows excellent odor removal.

## INSTALLATION

**IMPORTANT:** This media filter will cause more of a restriction on your air handling system than a regular equipment filter, because of its increased efficiency. The pressure drop of a clean filter (Model FED-AMFM1625-A) at 50% of rated air flow is 0.066 inches W.C. The same filter at 100% of rated air flow is 0.217 inches W.C. As the filter collects contaminants, the pressure drop increases. This media filter is not recommended where the pressure drop is critical.

## LOCATION

Your Air Cleaner is adaptable to all residential forced air furnaces or cooling systems. The Air Cleaner must be installed in the return air duct close to the blower compartment. This location provides the most even air flow across the filter and allows the Air Cleaner to keep the system motor and fan clean.

## HUMIDIFIERS

A humidifier should be installed in the furnace warm air duct. However, it may be installed in the return duct without causing problems to your Air Cleaner. Care must be taken that the humidifier does not leak, as this may damage the media filter or cause mineral deposits to build up on the filter.

## AIR CONDITIONING

Whenever possible, your Air Cleaner should be installed upstream of the cooling coil. This will clean the air before it reaches the evaporator coil.

## GENERAL INSTALLATION STEPS

1. **Remove existing equipment filter and clean blower compartment:** Thoroughly clean the blower compartment, since your Air Cleaner cannot remove dirt from the blower chamber and distribution ducts.
2. **Leave sufficient room around your Air Cleaner:** There must be adequate room to remove the filter. Additional room must be left above the Air Cleaner, if it is to be upgraded to a High Efficiency Electronic Air Cleaner.

**NOTE:** Once your Air Cleaner has been installed, do not allow the placement of a new hot water heater, water softener, gas pipe, or electrical cable to be put in front of or within 12 in (30 cm) from the top of the Air Cleaner. Otherwise, this will not allow for the removal of the Air Cleaner filters, which are necessary for maintenance or upgrading later.

3. **Installing the cabinet:** Make sure rivets or screws do not protrude into the cabinet, causing filters to catch.
4. **Transitions:** When the air duct does not fit the Air Cleaner opening, a gradual transition is recommended to reduce air turbulence through the Air Cleaner and to increase its efficiency. There should not be more than 20° of expansion used on each side of the transition fitting, approximately 4 inches per running foot (10 cm per 30 cm).

**Do not reduce ductwork to fit a smaller Air Cleaner. This will increase the velocity of air flow and may decrease cleaning efficiency.**

5. **Turning vanes:** If the Air Cleaner is installed adjacent to an elbow or angle fitting, turning vanes are recommended to improve air distribution across the filter.
6. **Seal the joints in the return air system:** All joints between the Air Cleaner and the heating/cooling equipment should be sealed to prevent dust from entering the clean air stream.

**To improve the performance of your Air Cleaner, these simple steps should be followed:**

- Run your heating/cooling system fan continuously, on low speed if available, since your Air Cleaner only removes particulate matter which passes through to the filter.
- Remove furniture or carpets from the front of the return air grilles so that air moves freely to the heating/cooling equipment.

- Check the fan belt on the furnace blower and see that there is no more than approximately 1/2 in (1.3 cm) of play on each side. A loose belt slips on the pulley.

## MAINTENANCE

### CAUTION

Turn off your heating/air conditioning system fan before performing maintenance to your Air Cleaner.

The media filter needs to be replaced once or twice a year depending on the amount of contaminants in the air. If the filter is allowed to become too clogged, it may cause a restriction to the air flow through the system. This may cause poor circulation of conditioned air or the evaporator coil of the air conditioning system to freeze up.

1. Remove Air Cleaner door.
2. Remove filter and discard.
3. Install new filter. Arrow must point toward the system fan.
4. Close Air Cleaner door.

### Replacement Media Filters

FEDAMU1620-	Part #FEDM0-1056
FEDAMU1625-	Part #FEDM1-1056
FEDAMU2020-	Part #FEDM2-1056
FEDAMU2025-	Part #FEDM8-1056

## ACTIVATED CARBON FILTERS

Activated Carbon filters are used for the removal of household odors. Carbon filters should be replaced every 3 to 6 months. Remove plastic bag from filters before installing. **Carbon filters are not washable.**

1. Turn off system fan.
2. Remove the filter from Air Cleaner.
3. Slide out old carbon filters.
4. Space the new carbon filters at equal distance across the discharge opening. Never put more than three (3) carbon filters in the unit.
5. Turn on system fan.

When replacement filters or carbon filters are required, contact your original installer or dealer.

### Replacement Carbon Filters

CQAMU1620-A, CQAMU1625-A	Set of 3 Part #1156-3
CQAMU2020-A, CQAMU2025-A	Set of 3 Part #1856-3

## UPGRADE TO ELECTRONIC AIR CLEANER

This Media Air Cleaner upgrades to an Electronic Air Cleaner, with a kit available from your installer.

- Utilizes existing cabinet for installation savings.
- Removes particulate such as tobacco smoke, bacteria and viruses down to 0.01 micron (1/2,540,000 of an inch).
- Lifetime filter system simply washes clean.

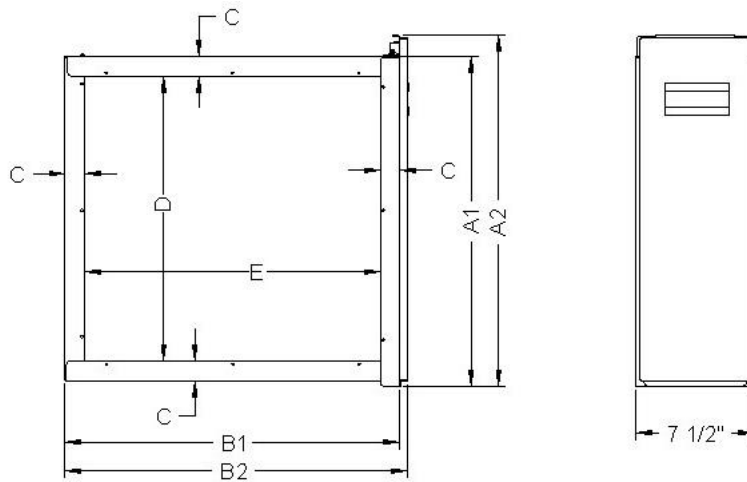

MODEL	DIMENSIONS in (cm)						
	A1	A2	B1	B2	C	D	E
<b>CQAMU1620-A</b>	15.94 (40.5)	17.41 (44.2)	23.18 (58.9)	23.7 (60.2)	1.25 (3.2)	13.12 (33.3)	20.68 (52.5)
<b>CQAMU1625-A</b>	15.94 (40.5)	17.41 (44.2)	26.11 (66.3)	26.64 (67.7)	1.0 (2.6)	13.62 (34.6)	24.11 (61.2)
<b>CQAMU2020-A</b>	20.83 (52.9)	22.3 (56.6)	21.21 (53.9)	21.74 (55.2)	1.25 (3.2)	18.0 (45.7)	18.71 (47.5)
<b>CQAMU2025-A</b>	20.83 (52.9)	22.3 (56.6)	25.76 (65.5)	26.29 (66.8)	1.25 (3.2)	18.0 (45.7)	23.26 (59.1)

**HIGH EFFICIENCY MEDIA RETROFIT AIR CLEANER  
LIMITED LIFETIME WARRANTY**

**LIFETIME WARRANTY** -- This FEDDERS™ USA product is warranted to the original owner, to be free from defects in material and workmanship, under normal use and maintenance, for the lifetime of the product except, however, for the disposable media filter which will have to be replaced from time to time, depending upon the use. This FEDDERS™ USA product must not have been moved from the site of original installation. A new or remanufactured part to replace the defective part will be provided without charge for the part itself, through an authorized FEDDERS™ USA service dealer, provided the defective part is returned to the FEDDERS USA™ service dealer **prepaid**, together with the **serial number, date of installation, and proof of purchase**. Defective parts must be packaged well and depending on the part, may require images emailed prior to shipping, to confirm condition of parts. If goods arrive damaged due to improper packaging, warranty will be void. The replacement part assumes the unused portion of the warranty.

**THIS WARRANTY DOES NOT INCLUDE ANY ADDITIONAL LABOR ALLOWANCE OR OTHER COSTS** incurred for diagnosis, repairing, removing, installing, shipping, servicing, or handling of either defective parts or replacement parts. Such costs may be covered by a separate warranty provided by the FEDDERS™ USA dealer.

**LIMITATIONS OF WARRANTY** -- All implied warranties (including implied warranties of merchantability) are hereby limited in duration to the period for which the limited warranty is given. The expressed warranties made in this warranty are exclusive and may not be altered, enlarged, or changed by any dealer or other person whatsoever.

**FEDDERS USA -- WILL NOT BE RESPONSIBLE FOR:**

1. Normal maintenance including replacement of filters, as outlined in the Owner's Manual.
2. Damage or repairs needed as a consequence of any misapplication, faulty installation, abuse, improper servicing, unauthorized alteration, or improper operations.
3. Damage as a result of floods, winds, fires, lightning, accidents, corrosive atmosphere, or other conditions beyond the control of FEDDERS USA .
4. Parts, including filters not supplied or designated by FEDDERS USA .
5. FEDDERS USA products installed outside the continental including Mexico, Canada, Alaska and Hawaii.
6. Any personal injury, special indirect or consequential property or commercial damage of any nature whatsoever.

**Model No.**

**Serial No.**

**Date of Installation**

**Installed By**

**Owner's Name & Address**

RETAIN THIS CERTIFICATE WITH YOUR DOCUMENTS

12/2021

[sales@feddersusa.net](mailto:sales@feddersusa.net)

[www.feddersusa.net](http://www.feddersusa.net)